

TIN KNOCKER

TK 816 LEAF BRAKE

INSTRUCTIONS & PARTS DIAGRAM



TAAG INDUSTRIES CORP.

1550 SIMPSON WAY, ESCONDIDO, CA 92029

Tel: (800) 640-0746 Fax: (760) 727-9948

Website: www.tinknocker.com Email: info@taagind.com

**TIN KNOCKER
SAFETY RULES
TK 816 LEAF BRAKE**

1. Never use a machine or tool for anything other than its intended purpose. Use the proper tool and equipment for the task.

2. Do not operate the machine in excess of its rated capacity.

WARRANTY

All new machines are sold with a one-year limited warranty, on factory defective parts. The warranty is limited to the original user. TAAG Machinery Co. at its option, will repair, replace or refund the purchase price of any part, tool or machine that fails during the warranty period. TAAG Machinery Co. will pay normal shipping charges for replacement parts. After 90 days from date of purchase, all express or overnight delivery charges are the responsibility of the customer. Purchaser must deliver to TAAG Machinery Co., at the address below, any written claim, with proof of original purchase. Replacement parts will be invoiced to purchaser and credit issued when the failed part is delivered to TAAG Machinery Co. Removal, reinstallation or replacement parts shall be at purchasers' / user's expense. Failure due to improper use of the machine voids the warranty.

NOTE: 1. This machine has been tested and adjusted prior to shipment, but can and often does require readjustment due to vibration and bouncing during transport. Following the procedures described within can easily do readjustment. These are procedures with which you, as a user, should be familiar, as you will use them repeatedly over the life use of the machine. If you have difficulty in performing these procedures, we are here to support you. Call us at: (800) 640-0746.

2. Opening rolls (for Philipsburg Lock) are consumable items and not subject to warranty.

TAAG INDUSTRIES CORP.

"The Tin Knocker People"

1550 Simpson Way

Escondido, CA 92029

Tel: (800) 640-0746 Fax: (760) 727-9948

Website: www.tinknocker.com * Email: info@taagind.com

TK 816 Leaf Brake

RECEIVING THE MACHINE

Inspect before signing Bill of Lading.

Upon receipt closely examine the Leaf Brake for damage during shipment. Any loss or damage should be noted in detail on the delivery receipt and reported to your distributor immediately. Free replacement from TK International is dependant upon the notation and the Bill of Lading on delivery slip.

INSTALLING THE MACHINE

Locate the Leaf Brake in a well-lighted area on a solid, level floor. The Leaf Brake must be securely bolted to the floor. Be sure you have adequate room to swing both handles and Bending Leaf.

PRECAUTIONS

DO NOT use the Leaf Brake to bend rods, nails or wires. This will cause damage to the edge of the top blade. DO NOT exceed the capacity of the Leaf Brake.

OPERATING & ADJUSTMENT OF THE TK 816

Adjusting for Metal Thickness

Clearance for bends is obtained by moving Top Leaf back at bending edge. If material is to be bent is within four gauges of capacity, move the Top Leaf back twice the thickness of the material. With lighter material, move Top Leaf proportionately forward if sharper bends are desired.

1. Unclamp Handles (H) slightly.
3. Loosen Top Adjustment Plate Bolt (N). Adjust Top Leaf with Top Adjustment Bolts (L). Tighten Locking Nuts and Top Adjustment Plate Bolt (N). Clamping pressure of the Links (K) is changed by adjusting the Nuts. (M)

Duplicate Bends

Adjustable Stop Gauge (O) may be positioned at any point on Rod (P) by means of Lock Bolt (Q) to limit the degree of bend.

Counterbalance

Counterweight (J) can be raised or lowered on Rod to properly counterbalance the Bending Leaf.

Overbending Adjustment

If sheet bends over further on one side than the other/ set the Top Leaf back on the end where sheet is overbending.

1. Unclamp Handles (H) slightly on side that is over bending.
2. Adjust Top Leaf with Top Adjustment Bolts (L).
3. Reclamp Handle (H).

Creeping Top Leaf Adjustments

Should Top Leaf creep forward when clamping material:

1. Check that brake sets level on floor.
2. Check Top Adjustment Plate (M) and Top Adjustment Bolts and Lock Nuts (L) to eliminate any movement of step bracket (15).
3. If still creeping, wedge under rear of Leg (A) at end that creeps until stopped. Replace wedge with permanent block of correct height.

Capacity:

The bending capacity of the brake is determined by the bending edge thickness provided by the Bending Leaf Bars (U/V) when mounted on Leaf.

1. Insert Bar (U) with Angle Bar (V) allow the full rated 1" minimum flange on capacity material.
2. Insert Bar alone without Angle Bar reduces capacity of brake four gauges.
3. Removing both Insert Bar and Angle Bar reduces capacity of brake seven gauges. These Bars are removed only to make narrow offset bends.

Narrow Offset Bends

Remove Angle Bar (V) and Insert Bar (U) - use Bending Leaf only.

Cautions

Bend short pieces of material in center of brake to equalize the strain. Never bend against seams unless Links (K) are adjusted to clamp the full multiple thickness of seam; and Top Leaf is set back for clearance of the same full multiple thickness. Always have both Angle Bar (V) and Insert Bar (U) mounted to Leaf when making capacity bends. When forming sections of wide girth such as cornices, to equalize the buckles in the sheet:

1. Start bend near the center of sheet, or,
2. Make a kink in the opposite end of sheet from the bend first made.

Sheets are not always perfectly flat and a buckle left in one end while the other is straightened by clamping in the brake will throw the first bend out of line when it, in turn, is straightened.

Always use material with square-sheared edges - rolled-edges will cause material to bow.

Never use brake to bend rods - these will nick Nose Bar. Always adjust for differences in the metal gauges. **Never** force-clamp the material.

Lubrication

Lubricate occasionally with SAE-30 oil.

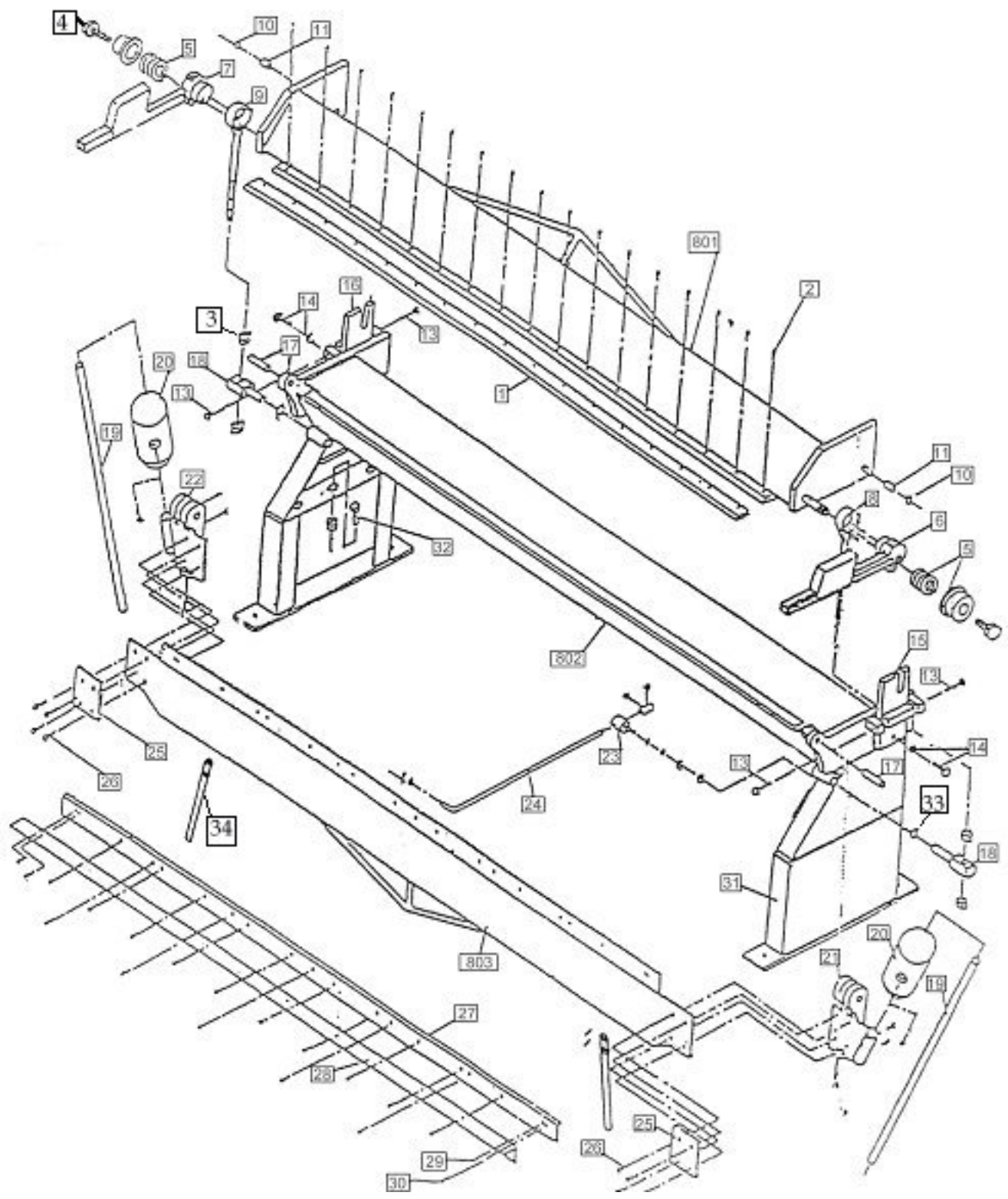

Parts For 816 Leaf Brakes

Fine No.	Part No.	Description	No. REQ"D.
801	816101	801 Holddown Assy.	1
1	816102	Top Blade	1
2	816103	Screw	17
3	816134	Toggle Assy. Nut	4
4	816104	Spring Cover Assy. Bolt	2
5	816105	Spring Cover Assy.	2
6	816106	Clamp Handle R.H.	1
7	816107	Clamp Handle L.H.	1
8	816108	Toggle Assy. R&L	1
9	816109	Toggle Assy. R&L	1
10	816110	C-Clip	2
11	816111	Bushing	2
802	816112	802 Base Assy.	1
13	816113	Screw	4
14	816114	Locknut & Washer	2
15	816115	Step Bracket Comp. R.H.	1
16	816116	Step Bracket Comp. L.H.	1
17	816117	Pin	2
18	816118	Swivel Pin Assy.	2
19	816119	Rod	2
20	816120	Counterweight	2
21	816121	Support, Apron Assy. R.H.	1
22	816122	Support, Apron Assy. L.H.	1
23	816123	Gauge Stop	1
24	816124	Gauge Rod	1
803	816125	803 Apron Assy.	1
25	816126	Plate, Fixing	2
26	816127	Screw, Fixing	8
27	816128	Insert Bar	1
28	816129	Angle Bar	1
29	816130	Flat Head Screw	12
30	816131	Screw	7
31	816132	Stand	2
32	816133	Screw Assy.	6
33	816135	Snap Ring	2
34	816136	Lifting Handle	2